



INDUCTION MOTOR ROTOR FAULT DETECTION USING ENHANCED FEED FORWARD NEURAL NETWORK

Kapil Pawar, Prof. Vinay Pathak

¹Research Scholar of Power System, ²Head of department

Department of Electrical Engineering

BITS, Bhopal (M.P), India

itlkapil93@gmail.com

Abstract—This Induction motor rotor fault detection is one of hot topic in between researchers in the last decade. Reason beside this maintenance of induction motor is the major concerns in modern industry where failure detection on motors increases the useful life cycle on the machinery. Broken rotor bars are among the most common failures in induction motors. Early detection of faults in electrical machines are imperative because of their diversity of use in different fields. A suitable fault monitoring scheme helps to stop propagation of the failure or limit its escalation to severe degrees and thus prevents unscheduled downtimes that cause loss of production and financial income. Detection of broken rotor bar of induction motor with the help of ANN was the focus of the proposed work. The mathematical models of induction motor in both healthy as well as fault condition were developed in order to simulate the faults of varying intensity at different load conditions. Various parameters of induction motor are recorded in all the different conditions. These recorded parameters are used to train the Artificial Neural Network. The output of the ANN shows that proposed technique successfully detects the presence of broken rotor fault of induction motor. Shows better values 10^{-1} error at 10 epochs. Also discuss Response Time of proposed ANN detection is good as compare to other previous method. Mathematical model helps of understand the basic model. The proposed shows good result as compare different methods of fault detection like SVM, fuzzy logic, DWT, FFT based.

IndexTerms - Induction Motor Faults, Fault Detection, Rotor Fault Analysis and Identification, Broken Rotor Bar, Artificial Neural Network and Diagnosing Techniques.

I. INTRODUCTION

Induction motors are most widely used industrial load and consumes a major part of overall electrical consumption. Fault identification in electrical machines and power systems is increasing interest research area for academicians as well as for industry. The wide variety of environments and conditions motor exposed to, mis-operations and manufacturing defects can make it subject to incipient faults or gradual deterioration and can lead to motor failure if left undetected. Most electric motor failures interrupt process, reduce production and may damage related machinery. Sometimes a small HP motor failure can also create hours of plant stoppage in continuous processing.

The Squirrel cage induction motors are most widely used electrical machines for industrial, domestic and commercial applications. These motors have advantages such as

robustness, simplicity of its construction and highly reliable [1-2]. Since, Induction motors are undoubtedly reliable but we cannot avoid the possibility of failure also. These failure conditions are taking place because of its component failure. If the failure occurs in the machine that failure ought to be diagnose as early as possible. If these failure conditions are not diagnosed on time, the failure component will affect whole motor operation badly and will become more catastrophic. Consequently, large revenue losses and maintenance will be needed [5].

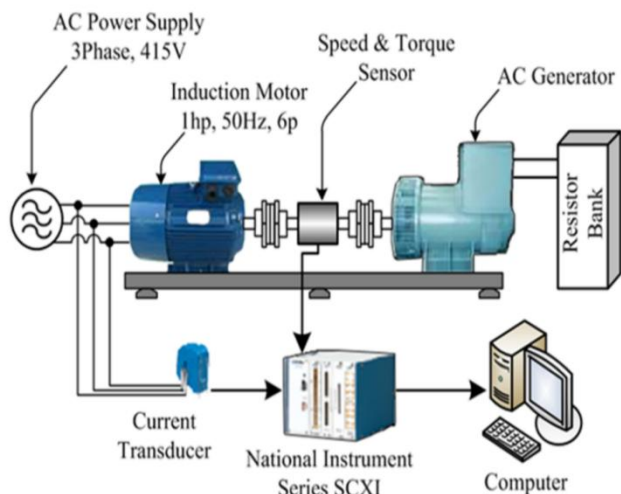

Fig .1: Shows the Fault Detection Setup

II. FAULT DETECTION

In the Koalas Sa Nyutta an Automated fault diagnostics and condition monitoring are important parts of most of the world's industrial processes. It is difficult to develop an analytical model that adequately describes induction motor performance in its all operation points with any power source in case of induction motor fault identification. If the expert knowledge of process is available a simple signal-based diagnostic can be adopted with knowledge-based models. It is difficult for a human expert to distinguish fault from the normal operation. Multiple information sources may need for accurate decision. Thus, the data-based models are the most interesting approach for the induction motor diagnostics [10]. In this presented work, the fault identification system is built using RMS features retrieved from the voltage and current signals and decision making part relies on data-based (pattern) classification model.

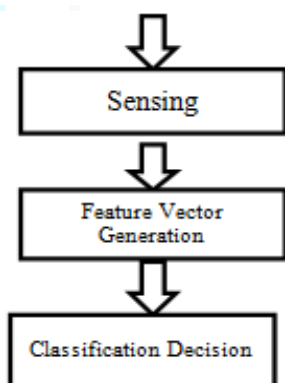

Fig 2: Basic Pattern Recognition System

III. ANN BASED APPROACH

The proposed ANN Based method deals with the detection of broken rotor bar of an induction motor. The problem is approached through mathematical modeling of induction motor. Both the models, for healthy as well as faulty motor,

are developed using MATLAB Simulink. The model is used to simulate different conditions of fault with varying number of broken bars. Parameters like three-phase voltage, 3 phase current and THD of all voltages and currents are acquired from the simulated model. The data thus generated is used to train Artificial Neural Network which diagnoses the condition of motor. The results obtained prove the effectiveness of proposed method. Detection of broken rotor bar of induction motor with the help of ANN was the focus of the paper. The mathematical models of induction motor in both healthy as well as fault condition were developed in order to simulate the faults of varying intensity at different load conditions. Various parameters of induction motor are recorded in all the different conditions. These recorded parameters are used to train the Artificial Neural Network. The output of the ANN shows that proposed technique successfully detects the presence of broken rotor fault of induction motor [01].

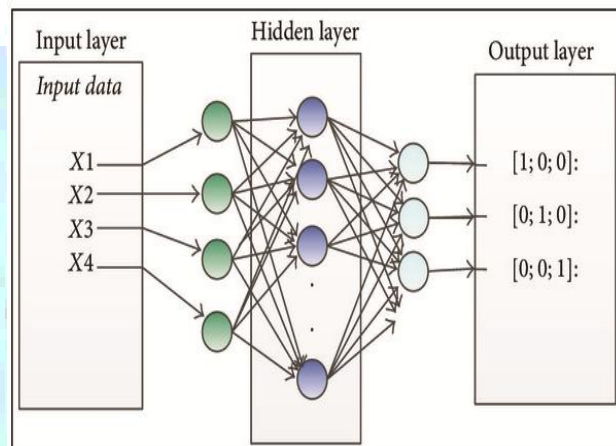

Fig. 3: ANN based Motor Rotor Fault Detection

In fact, fuzzy logic is reminiscent of human thinking processes and natural language enabling decisions to be made based on vague information. Therefore, this paper applies fuzzy logic to induction motors fault detection and diagnosis. The motor condition is described using linguistic variables. Fuzzy subsets and the corresponding membership functions describe stator current amplitudes. A knowledge base, comprising rule and data bases, is built to support the fuzzy inference. The induction motor condition is diagnosed using a compositional rule of fuzzy inference. Experimental results are presented in terms of accuracy in the detection motor faults and knowledge extraction feasibility. The preliminary results show that the proposed fuzzy approach can be used for accurate stator fault diagnosis. In this paper, the realization of the fault in stator winding in a three-phase induction motor has been considered. In the first place, the induction motor was simulated by dynamic equations to that effect; afterwards, the equations were revisited by accounting faults in one of the phases. As for the issue of fault realization, the fuzzy logic and its application in clustering have been used. As an advantage of this method, we can refer to its high accuracy,

online state as well as its deprivation from an accurate model for the system [02].

IV. PROPOSED MATHEMATICAL MODELLING OF ANN BASED SYSTEM

The Modelling of induction motor with broken rotor bar fault. Rotor faults represent broken rotor bar, damage in during, etc. The focus here is on broken rotor bars. In the condition of broken rotor bar fault all the equations of healthy motor would remain as it is except the rotor impedance. When fault occurs, the rotor impedance will increase. But, as the change in reactance is very small, hence is being neglected here. So the equation of rotor resistance will be modified as derived below [9]:

$$r_r = \frac{R_b}{N/3} \frac{1}{K^2} \quad 1$$

Let r_r rotor resistance referred to stator

N = total number of rotor bars

n = number of broken rotor bars

Where, k is the transformation ratio. The rotor resistance, after considering n number of broken bars, becomes

$$r_{r1} = \left(\frac{R_b}{\frac{N}{3} - n} \right) \frac{1}{K^2} \quad 2$$

Now, change in rotor resistance

$$\Delta r = \frac{3n}{N - 3n} \times r_r \quad 3$$

The end rings and the magnetizing current are not taken into account [10]. So, the equations for rotor becomes

$$\frac{d \lambda_{qr}}{dt} = -(r_r + \Delta r) \cdot i_{qr} - (\omega - \omega_r) \lambda_{dr} \quad 4$$

$$\frac{d \lambda_{dr}}{dt} = -(r_r + \Delta r) \cdot i_{dr} - (\omega - \omega_r) \lambda_{qr} \quad 5$$

The below figure shows the Mathematical Model of induction motor for broken rotor bar system. In this model there are three sub system available: Q – block, D – Block and Rotor Block. In below shows the subsystem of D, Q and rotor block. That is in above figure 4.

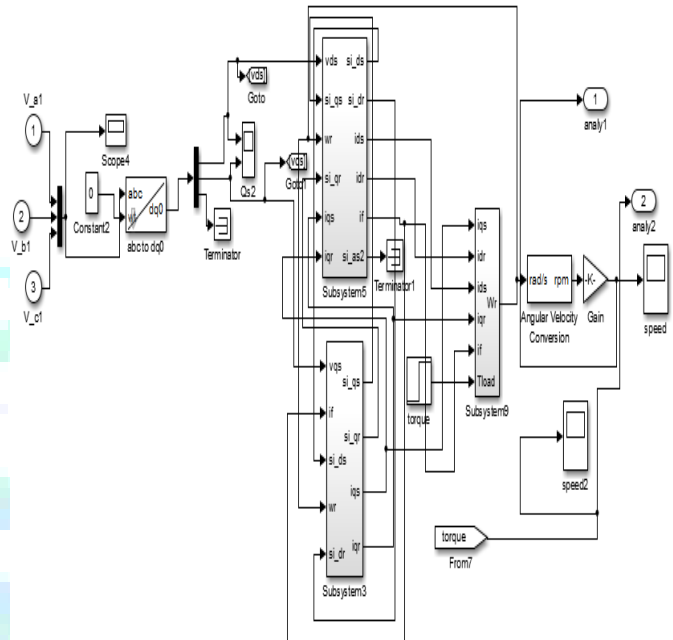

Fig. 4: Shows the Mathematical Model of Induction Motor

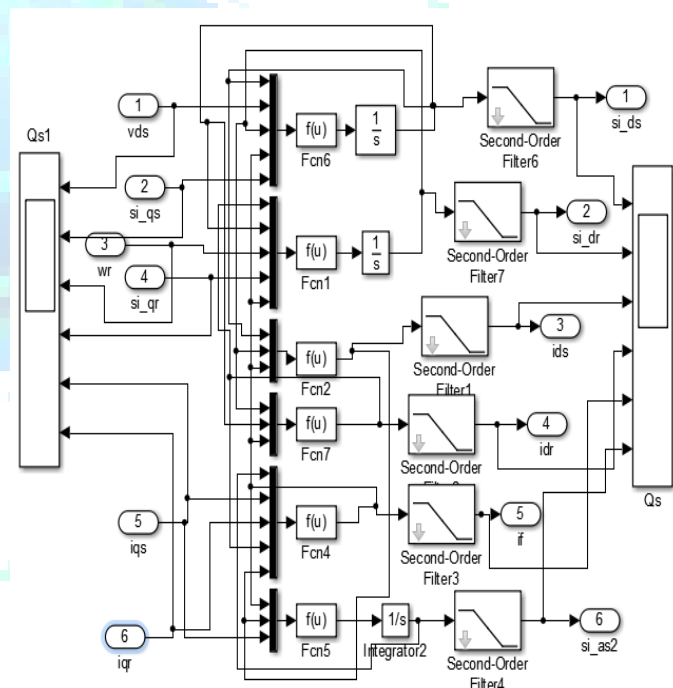

Fig. 5 Sub block of d block

V. SIMULATION AND RESULTS

In the above figure 5 is the main model of proposed method is contain different sub system sub systems are describe at proposed model.

Parameters used for diagnosis

In the below figure 6 and figure 7 shows the block parameters of rotor measurement and stator measurement of motor. Shows in below. There are different parameters are masked in the list which we want to analyzed for training data and train data base required. The main focus of stator current, rotor current and torques.

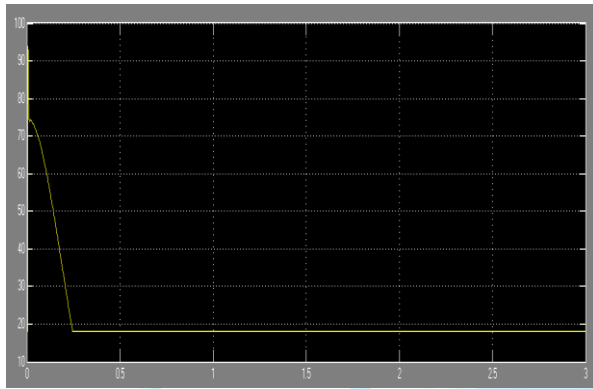

Fig .6: Shows the Different parameter for analysis Speed



Fig .7: Shows the Different parameter for analysis Torce

There are different parameters are shown in the above figure like total number of broken rotor bar, number of poles, rotor inductance and others. In the proposed thesis work focused on broken rotor bar because when broken rotor bars are breaking they directly affected the health on induction motor health. Induction motor health is directly depended on the rotor bar. In this proposed simulated work focused on the induction motor heath assessment in different broken rotor bar conditions. Total number of broken rotor bar in the induction motor in twenty-eight. For the analysis simulate the proposed model up to 1000 times and collect the different data of motor

under different broken rotor bar condition. Use this data to analyze in the unreal network tool box in matlab.

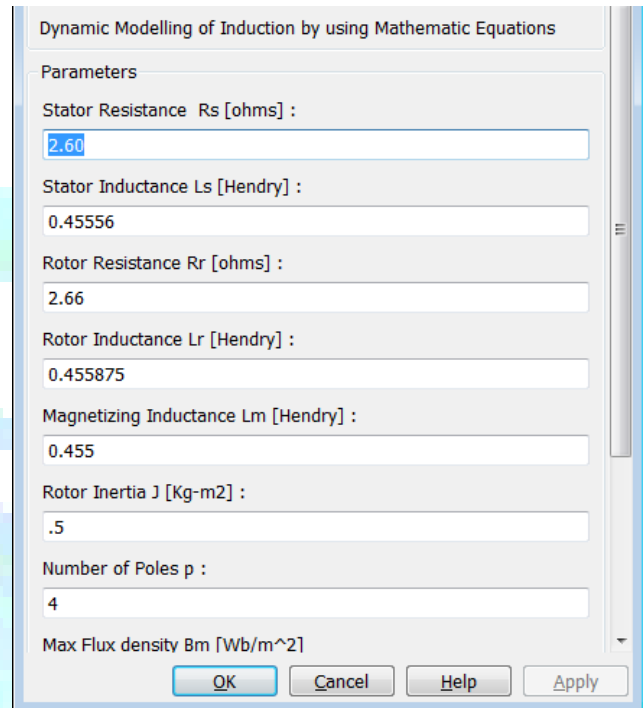

Fig. 8: Induction motor and its parameters

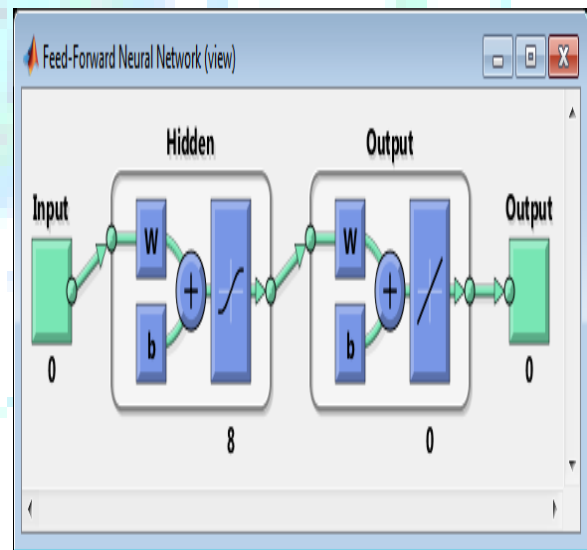

Fig. 10: Used Neural Network

For the analyzed of the proposed system use a feed forward neural network. There is different type of neural networks available according the inner level of complexity use a different network. Output of Mean Square Error.

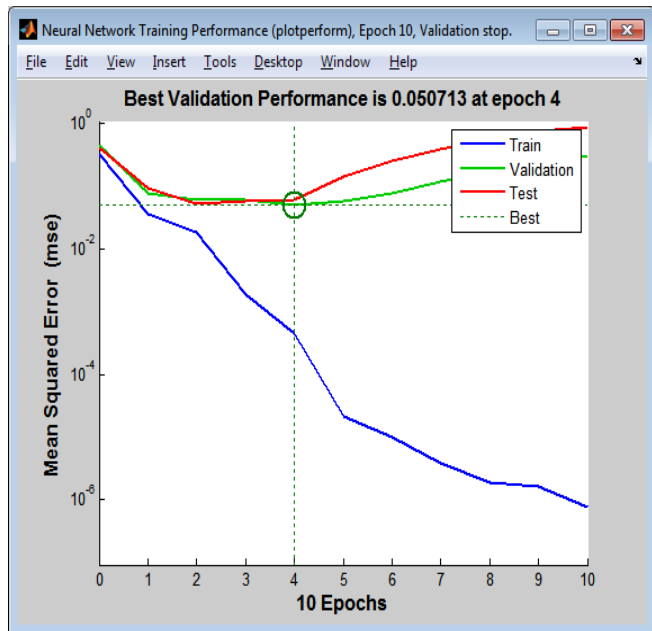

Fig. 11: Shows the Optimum performance

The above figure 11 shows the mean square error of proposed method. There are four lines shows in the figure train data, validate data, testing and best or optimum result. The above figure shows the optimum performance output. The presented system for motor rotor fault detection best value of optimization using ANN is 10^{-1} . Shown in above figure. Its shows response time system. The above graph is created in between x and y axis. X axis shows the number of epochs and y axis shows the error mean square error. Optimum result obtains with low value of error as compare to pervious method.

Result Comparison

Table I Result Comparison

| S. No. | Parameters | Previous method [01] | Proposed Method |
|--------|---------------------|---------------------------|-------------------|
| 1 | Mean Square Error | 10^{-10} | 10^{-6} |
| 2 | Epochs | 180 | 10 |
| 3. | Best Optimum Result | 170(Epochs) at 10^{-10} | 4(Epochs) at 0.04 |
| 4. | Number of Samples | 12500 | 1000 |

In the above figure shows the ANN over simulated results at the different broken rotor bar conditions.

Table II. Broken Rotor Bar based Comparison

| | | |
|-------------------------|--------|------------------------------------|
| Under Good Condition | 0 to 5 | Induction motor in good condition |
| In between Good and Bad | 5 to 8 | Induction motor started broken age |

| | | |
|---------------------|---------|-----------------------------|
| Under Bad Condition | Above 8 | Replace the Induction motor |
|---------------------|---------|-----------------------------|

V. CONCLUSION

Detection of broken rotor bar of induction motor with the help of ANN was the focus of the presented work. The mathematical models of induction motor in both healthy as well as fault condition were developed in order to simulate the faults of varying intensity at different load conditions. Various parameters of induction motor are recorded in all the different conditions. These recorded parameters are used to train the Artificial Neural Network. The output of the ANN shows that proposed technique successfully detects the presence of broken rotor fault of induction motor. Shows better values 10^{-9} error at 1000 epochs. Response Time of proposed ANN detection is good.

REFERENCES

- [1] Kumar, Prashant, and Ananda Shankar Hati. "Deep convolutional neural network based on adaptive gradient optimizer for fault detection in SCIM." *ISA transactions* 111 (2021): 350-359.
- [2] Zare, Samira, and Moosa Ayati. "Simultaneous fault diagnosis of wind turbine using multichannel convolutional neural networks." *ISA transactions* 108 (2021): 230-239.
- [3] Khanjani, Majid, and Mehdi Ezoji. "Electrical fault detection in three-phase induction motor using deep network-based features of thermograms." *Measurement* 173 (2021): 108622.
- [4] Garcia-Calva, Tomas A., et al. "Rotor Fault Detection in Inverter-Fed Induction Motors Using Speed Analysis of Startup Transient." 2019 IEEE 12th International Symposium on Diagnostics for Electrical Machines, Power Electronics and Drives (SDEMPED). IEEE, 2019.
- [5] Quiroz, Juan C., et al. "Fault detection of broken rotor bar in LS-PMSM using random forests." *Measurement* 116 (2018): 273-280.
- [6] Jerkan, DejanGojko, Dejan D. Reljić, and Darko P. Marčetić. "Broken rotor bar fault detection of IM based on the counter-current braking method." *IEEE Transactions on Energy Conversion* 32.4 (2017): 1356-1366.
- [7] Liu, Yiqi, and Ali M. Bazzi. "A review and comparison of fault detection and diagnosis methods for squirrel-cage induction motors: State of the art." *ISA transactions* 70 (2017): 400-409.
- [8] Bharath. References Rakeshkumar A. Patel, Dr. B.R. Bhalja , "Induction Motor Rotor Fault Detection using Artificial Neural Network", Con, IEEE, 2015.
- [9] Marius Media, BogdanVenescue, "Induction motor rotor cage diagnosis with Stockwell and Wavelet time frequency stator current analysis", U.P.B. Sci. Bull., Series C., Vol. 75, Issue 4, 2013.
- [10] Monia BenKhad r Bouzid, "New expressions of symmetrical components of the induction motor under stator faults", *IEEE Transactions on Industrial Electronics*, Vol. 60, No. 9, 2013
- [11] Hamid FekriAzgomi, JavadPoshtan, "Induction motor stator fault detection via Fuzzy Logic", 21st Iranian Conference, IEEE , 2013.
- [12] Carlos Pezzani, Pablo Donolo, Guillermo Bossio, Marcos Donolo, Armando guzman, Stanley E. Zocholl, "Detecting broken rotor bars with zero setting protection, 48th industrial & commercial power systems technical conference IEEE, 2012.

- [13] Phase current”, 15th International Power Electronics and Motion Control Conference, Europe, 2012.
- [14] S. Hamdani, H. Mezerreg, B. Boutikar, N. Lahcene, O. Touhami and R. Ibtouen, “Rotor fault diagnosis in a squirrel cage induction machine using Support Vector”, International conference on Electrical Machines IEEE, 2012.
- [15] “Design of Support Vector Machine classifier for broken bar detection”, IEEE International Conference on Control Applications, 2012.
- [16] Y. Han and Y. H. Song, “Condition monitoring techniques for electrical equipment- A literature survey”, IEEE Transactions on Power Delivery, Vol. 18, No.1, 2003.
- [17] P.C. Krause, O. Wasynczuk, S.D. Sudhoff, “Analysis of Electric Machinery and Drive Systems”, IEEE Press, New York, 1996.
- [18] Filippetti, F.; Martelli, M.; Franceschini, G.; Tassoni, C, “Development of expert system knowledge base to on-line diagnosis of rotor electrical faults of induction motors”, Conference Record of the IEEE Industry Applications Society Annual Meeting, 1992.